

HIGH/LOW PRESSURE SENSOR - HLR 7970T

(NACE Certified Usage, Panel Mount)

Applications: High (PSH/PSHH) or Low (PSL/PSLL)

Adjustment Range Capability of 10 to 10,000 PSI (.689 - 689.5 Bar)

Designed to be programmed as either a High (detect and react to rising/increasing pressure) or as a Low (detect and react to a falling/decreasing pressure). The HLR 7970T is a two position, three way Universal ported (H, O, L), automatic reset (spring return), pressure balance spool, flow control valve. Within standard safety systems, Pressure Sensors monitor a specific media or process pressure source for a deviation from the normal operating range. The Pressure Sensor's loss of control circuit pressure will initiate a shutdown sequence (safety valve closure) or provide an alarm. Pressure Sensors can also be used to indirectly operate on/off, flow control valves or pneumatic driven pumps.

Special Features: All components necessary for four (4) different piston arrangements are installed within this self-contained unit. Components that are not installed in the current piston arrangement, are kept in an enclosed Storage Tube. The Pressure Sensor also has a convenient 1/8"-27 N.P.T. "Female" process connection installed in its Piston Housing.

Reason To Use: Our Pressure Sensor's patented mechanical advantage eliminates the need to purchase and store additional "matching Piston and Spring combination" sets. Installing or reorienting our piston components into specific "Piston Arrangements" allows an adjustment range capability of 10 to 10,000 PSI to be achieved. This feature is especially beneficial for remote facilities that require pressure setting changes to match new process conditions.

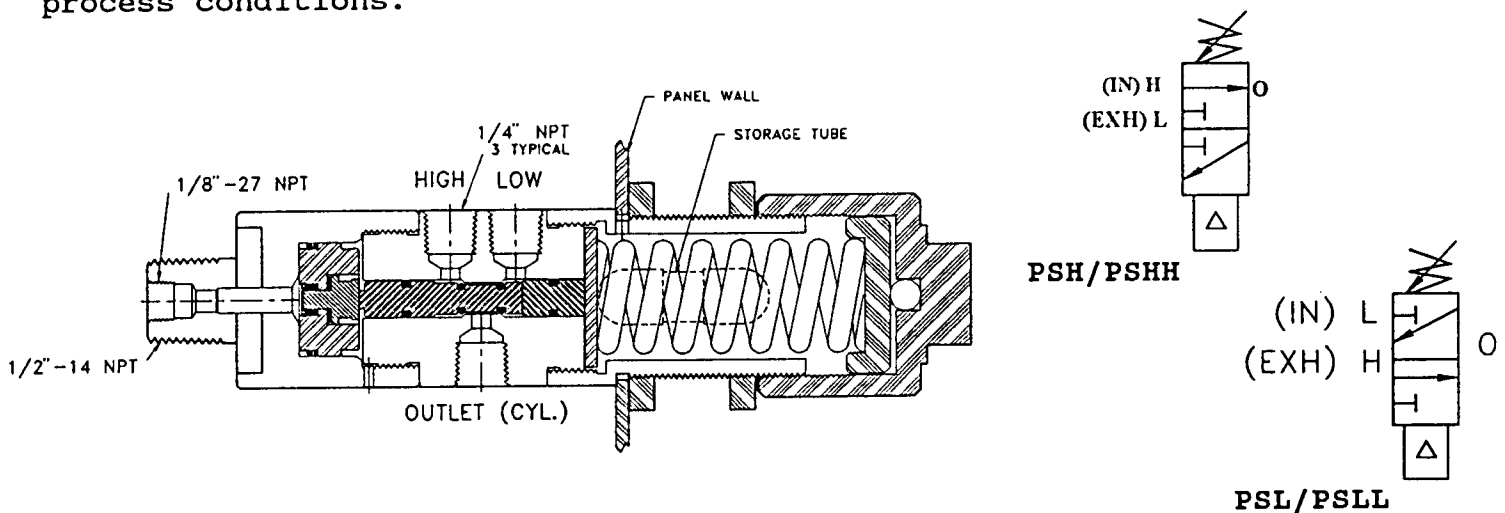

CHARACTERISTICS

1. Dimensions: 1.750" Dia. X 8.0" L.
2. Working Pressure:
Process Press. Inlet - 10,000 PSI Max. (689.5 Bar)
Control Ports - 125 PSI Max. (8.62 Bar)
3. Connections: Process Press. Inlet-1/2"-14 N.P.T."M"
1/8"-27 N.P.T."F"
Control Ports - 1/4"-18 N.P.T. "F"
4. Weight: 3.5 Lbs.. (1.6 Kg.)
5. Panel Hole "Cutout" Size Req.'ed.: 1 5/8" (39.81 mm)

HIGH/LOW PRESSURE SENSOR - HLR 7970T

A SELF CONTAINED UNIT (NACE CERTIFIED)

For Pressures From 10 to 10,000 PSI

(.689 - 689.5 Bar)

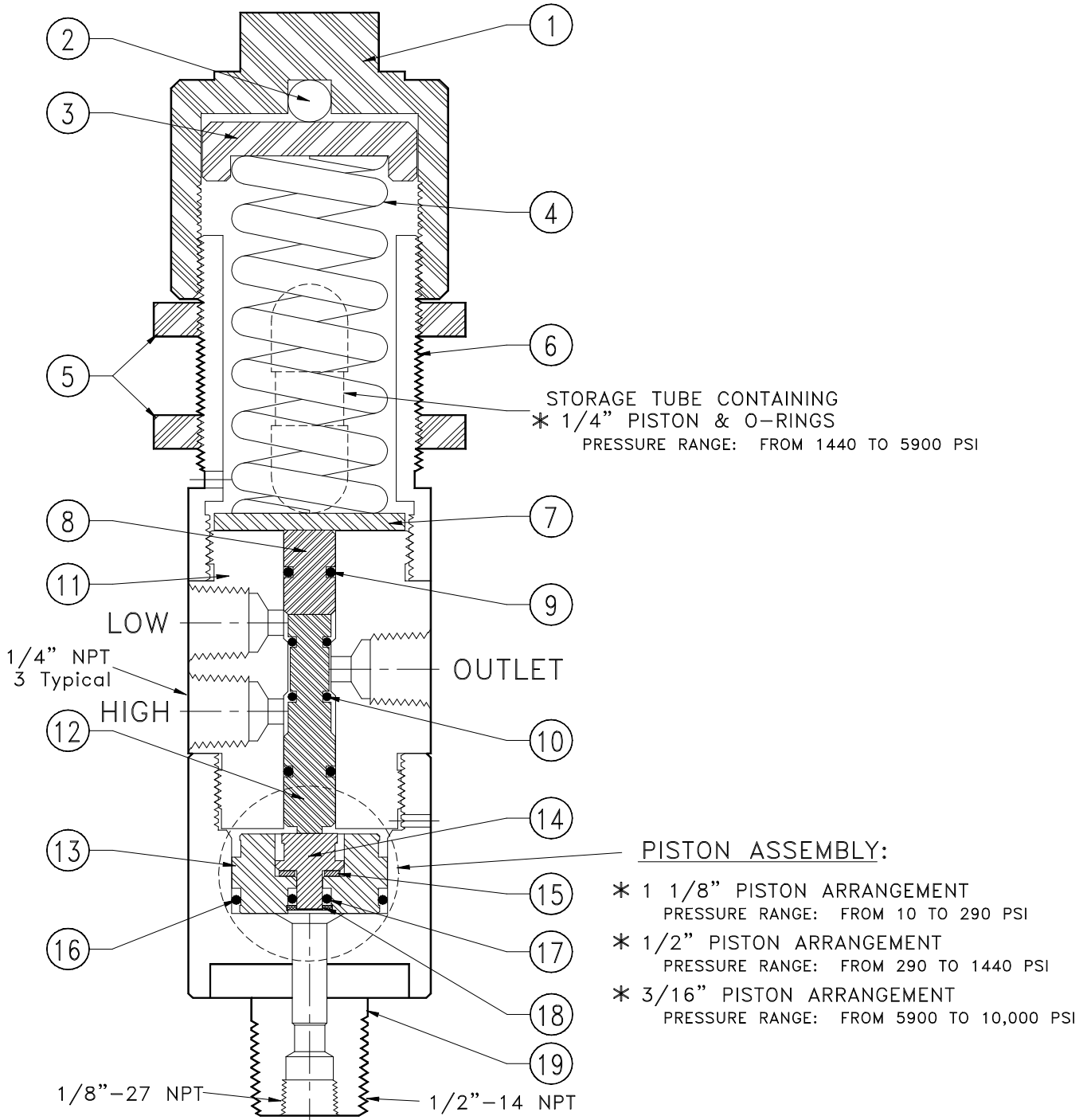

*This piston arrangement and pressure range may be obtained through a combination of rearranging the components in the current piston assembly and utilizing components in the storage tube. The following pages contain an enlarged and detailed view with material list for each piston arrangement.

HIGH/LOW PRESSURE SENSOR - HLR 7970T

The HLR 7970T Pressure Sensor is a pressure balance spool control valve used to respond to a predetermined pressure setting. In the Pressure Safety Low (PSL) mode, the valve functions as a 3-way, normally closed, block and bleed control. When used in the Pressure Safety High (PSH) mode, it functions as a 3-way, normally open, block and bleed control. The HLR 7970T is a unique self-contained control capable of responding to set pressure points from 10 to 10,000 PSI (.689 - 689.5 Bar).

BILL OF MATERIAL

ITEM	PART NAME	PART NUMBER	MATERIAL
1.	Adjusting Cap	79710A	Delrin
2.	Ball	5/16"D	316SS
3.	Spring Guide	79711A	Delrin
4.	Spring	HLR-1	302SS
5.	Lock Nut	79712A	Delrin
6.	Spring Housing	79709A	316SS
7.	Stop	79708	316SS
8.	Upper Stem	79707A	316SS
9.	O-Ring (2)	AS-010V75	Viton
10.	O-Ring (2)	AS-008V75	Viton
11.	Body	79704A	316SS
12.	Lower Stem	79706A	316SS
13.	Large Piston	79702MSGT	316SS
14.	Small Piston	79703A	316SS
15.	Spacer	79705	316SS
16.	O-Ring	AS-119T	Teflon
17.	O-Ring	AS-008T	Teflon
18.	Retainer Ring	.312IRR	316SS
19.	Piston Housing	79701A	316SS
20.	1/4" Piston	79713T	316SS
21.	O-Ring	AS-006T	Teflon
22.	O-Ring	AS-012T	Teflon

FEATURES

1. Dimensions: 1.750" Dia. x 8 " L
2. Working Pressure: Sensed Inlet - 10 - 10,000 PSI (.689 - 689.5 Bar).
3. Connections: Sensed Inlet - 1/2"-14 NPT"M"
1/8"-27 NPT"F"
Control 1/4"-18 NPT"F"
4. Weight: 3.5 lbs.
5. Panel Mount Detail: 1 5/8" Diameter hole required.

CAUTION

1. Do not disassemble while under pressure.
2. Remove spring tension to assemble or disassemble spring housing from body.
3. Do not plug control ports.

NOTE: A. Control performs best with low (30 PSI) pneumatic supply.
B. Extra parts for changing piston arrangements are stored in tube.
C. May be ordered individually or as a set with the HLR 8130 manifold.

PRESSURE SENSOR - HLR 7970T

NACE Service - Panel Mount

INTRODUCTION

The HLR 7970T Pressure Sensor is a two position, three way, automatic reset, pressure balance spool control valve used to respond to a predetermined Pressure Setting. In safety control systems, the Pressure Sensors initiate safety valve closure to safe guard facilities upon detection of abnormal pressure. In other applications, they are used to start/stop various control functions within particular pressure range limits.

All standard HLR 7970T Pressure Sensors have a pressure Adjustment Range from 10 to 10,000 PSI (.69 to 690 BAR). This is accomplished by use of the patented, self-contained, "variable size piston arrangement" concept. Piston sizes are varied by rearranging or orienting the exposed or inlet surface area to respond to particular pressure ranges. Varying the size of the surface area is accomplished by using piston components that literally slide within one another or having two of the parts that can rise or fall in unison. The patented piston assemblies are discussed in detail in the operation section.

HLR 7970T Series Pressure Sensors are commonly referred to as "Block and Bleed" Stick Pilots. They are especially well suited for the following applications:

1. Systems that could experience greater than normal operation pressure. Overpressuring ruptures diaphragms, helical coils and bourdon tubes.
2. Systems where the pressure detection requirements would vary greatly over a period of time. (Changing pressure settings required to match new operational conditions).
3. Systems that require a nonconstant bleed type control. (Some Bourdon tube Pressure Sensors are constantly venting during normal operation).
4. Areas subjected to vibration cause other Pressure Sensors with delicate balanced components to malfunction when shaken.

OPERATION

The major components and their functions are listed below:

ADJUSTING CAP: The Cap provides a means of applying the proper tension on the Spring. Turning or rotating the Cap clockwise (screwing down) increases spring tension which enables higher pressure to be set. Counterclockwise rotation of the Cap decreases spring tension and its compression.

SPRING: The Spring is compressed to provide a means of "balancing" or establishing a static position for the control's stem and piston assemblies. It also provides the automatic reset capabilities for the Pressure Sensor.

BODY: The Body portion essentially functions as a two position, three way, control relay. It provides a means of directing the flow path of the instrument supply pressure through the control ports. Further explanation of the Body follows in the Programmed Application section.

PISTON HOUSING: The Piston Housing provides the monitored pressure inlet connection and a chamber within which the piston assemblies can rise and fall as affected by process pressure exerted upon them.

PISTONS: The Piston assemblies are the components that are directly affected by the inlet media or process pressure. They move in response to force exerted upon them. O-ring seals are mounted directly on the piston assemblies.

Together the assembled components function in the following manner:

Desired pressure settings are accomplished by turning the Adjusting Cap (79710SS). As the Adjusting Cap is turned, the Spring (HLR 1) acts against the Stop (79708), the Upper Stem (79707), the Lower Stem (79706) and the Piston Assembly arrangement. Monitored pressure stabilized within the desired operational limit allows control instrument supply to flow through either the "H" or "L" port and the "O" port. A balance is established between the spring tension and the monitored pressure acting against the piston assembly. This static condition is maintained until the monitored media pressure either rises above or drops below the pre-selected operational pressure setting. Instrument supply keeps the pressure receiving device pressurized as long as the monitored pressure is within operational limits selected.

PROGRAMMED APPLICATIONS

The HLR 7970T can be used as either a High Pressure Sensor (PSH) or a Low Pressure Sensor (PSL). Control ports are stenciled "H", "L" and "O". Whenever the "High" (Pressure Increasing) application is required, the "H" port is utilized as the instrument supply inlet. For "Low" (Pressure Decreasing) applications, the "L" port is utilized as the instrument supply inlet. The "O" port always serves as the instrument supply outlet, which in turn, provides pressure for the "End Device" or receiving control to remain in operation.

PRESSURE SAFETY LOW

(PSL/DECREASING/"TRIP" ON FALLING PRESSURE)

In the Pressure Safety Low (PSL) mode of operation, the valve "Body" (PN 79704A) section functions as a 3-way, **Normally Closed**, block and bleed (exhaust) flow control. The connection stenciled "L" assumes the instrument supply **Inlet** function.

Since the Low connection functions as a **Normally Closed port**, instrument supply will communicate or flow freely through the Outlet "O" port whenever the inlet monitored pressure is **above** the Low (Decreasing) Setting. As the monitored pressure decreases below the **Low Pressure** setting, the stem shifts position, thus blocking the instrument supply Inlet or "L" port.

The accumulated control instrument pressure downstream of the pressure sensor "backbleeds" through the High (H) which now assumes the function of an exhaust or vent port.

PRESSURE SAFETY HIGH APPLICATION

PSH/INCREASING/"TRIP" ON RISING PRESSURE

In the Pressure Safety High mode of operation, the valve "Body" (PN 79704A) section functions as a 3-way, **Normally Open**, block and bleed (exhaust) flow control. The connection stenciled "H" assumes the instrument supply "**Inlet**" function. Since the High connection functions as a **Normally Open port**, instrument supply pressure will communicate or flow freely through the Outlet "O" port whenever the inlet monitored pressure is below the High (Increasing) setting. As the monitored pressure increases above the High Pressure setting, the stem shifts position thus blocking the instrument supply Inlet or "H" port.

The accumulated control instrument pressure downstream of the pressure sensor "backbleeds" through the Low (L) which now assumes the function of an exhaust or vent port.

PISTON ARRANGEMENTS

Each HLR 7970T Pressure Sensor, as stated previously, has a self contained, full compliment of piston assemblies to monitor pressures from 10 to 10,000 PSI. A Storage Tube is placed within each Spring. This Tube provides an excellent place for safe keeping of the O-Rings and other components which are not being utilized in the current piston assembly.

PISTON ARRANGEMENT NOTE

The HLR 7970T Series Pressure Sensor enables the facilities operator to switch pressure ranges or settings without having to purchase additional piston components and "matched" springs.

Each Piston Arrangement is further explained next.

1 1/8" PISTON ARRANGEMENT (PRESSURE FROM 10-290 PSI) (.69-20 BAR)

The piston's surface area that is subjected to movement by the incoming media (monitored) pressure is 1 1/8" in diameter. Three basic parts comprise the assembly necessary for reacting to pressures from **10-290 PSI**. These components are the **Large Piston (79702)**, **Small Piston (79703A)** and the **Spacer (79705)**. The Spacer essentially locks the Small Piston and Large Piston together.

As the monitored pressure enters the inlet of the Piston Housing, the entire assembly is lifted in unison. O-Ring seals engage the piston wall thereby securing monitored pressure to affect only the inlet base of the piston assembly.

**1/2" PISTON ARRANGEMENT (PRESSURE FROM 290-1440 PSI)
(20-99 BAR)**

The surface diameter of the piston assembly subjected to monitored pressure is 1/2" in diameter. This is accomplished by orienting the Small Piston (79703A) with 1/2" diameter surface placed toward the inlet of the Piston Housing. ***The Large Piston (79702) remains stationary while pressure moves the Small Piston only.*** O-Ring seals engage the wall to prevent passage of monitored pressure beyond the desired control area.

**1/4" PISTON ARRANGEMENT (PRESSURE FROM 1,440 - 5,900 PSI)
(99-407 BAR)**

The surface area of the piston assembly subjected to incoming media pressure is a 1/4" in diameter. A special bore is machined within the Piston Housing to accommodate the 1/4" Piston (79713). O-Ring seals on the 1/4" Piston engage the Piston Housing wall, thereby providing the necessary closure thus keeping monitored pressure contained within a restricted area. ***As pressure is introduced at the inlet of the Piston Housing, it lifts both the 1/4" Piston and Small Piston together in unison.*** The Large Piston (79702) remains stationary as the Small Piston slides up and down within its' bore.

**3/16" PISTON ARRANGEMENT (PRESSURE FROM 5,900 - 10,000 PSI)
(406-690 BAR)**

The 3/16" Piston Arrangement is similar in formation to the 1-1/8" Piston Arrangement previously described. Its' exception is that the Spacer (79705) is not utilized. Is is placed within the Storage Tube. Removal of the Spacer allows only the Small Piston to move, as it is affected by monitored pressure. ***The Large Piston remains stationary, essentially providing a guide within which the Small Piston slides.*** O-Rings strategically located provide the necessary seals.

A surface diameter of 3/16" is affected by monitored pressure.

INSTALLATION

WARNING: The user of HLR Controls, Inc. products must conform to all applicable mechanical, piping and other established national codes in the installation and operation of control valves.

Do not attempt to install or operate these devices without proper training in the technique or working on pneumatic, fluid power control, systems and other devices.

Prior to the installation of the HLR 7970T Pressure Sensor, it is recommended that the 1/2" NPT male threads of the Piston Housing and the 1/4" NPT male threads of the Tubing Connections be carefully Teflon taped.

It is also recommended that a light coat of "Swak" (Anaerobic Pipe Thread Sealant with TFE) be applied on the pipe threads whenever one Stainless Steel component is screwed into another. The Teflon Tape and special Thread Sealant will prevent "galling" or seizure and provide an excellent pressure seal.

~~MAINTENANCE~~

The HLR 7970T Series Pressure Sensors are designed for a service life of over twenty years. Seals used within the control have a shelf life of ten years. These seals are off-the-shelf items available from sources worldwide.

Scheduled maintenance is dependent upon the severity, frequency of use and cleanliness of the control (media) source. Established client preventive maintenance and safety system testing guidelines should be followed.

Should the control fail to perform satisfactorily after several years in service, an internal inspection is required.

CAUTION: BEFORE PROCEEDING WITH THE DISASSEMBLY OF ANY HLR CONTROLS, INC. PRODUCT, STRICT ADHERENCE TO YOUR FACILITIES ESTABLISHED SAFETY PROCEDURE FOR ISOLATING, TESTING OR EXHAUSTING PRESSURE FROM A CONTROL SYSTEM OR DEVICE IS REQUIRED.

MEDIA CONTROL SYSTEMS CONTAIN HIGH LEVELS OF STORED ENERGY. DO NOT ATTEMPT TO CONNECT, DISCONNECT OR REPAIR THESE PRODUCTS WHENEVER A SYSTEM IS PRESSURIZED.

NOTE: ALWAYS EXHAUST THE PRESSURE FROM THE SYSTEM BEFORE PERFORMING ANY SERVICE WORK. FAILURE TO DO SO CAN RESULT IN SERIOUS PERSONAL INJURY.

After the control system is properly isolated and depressurized the Pressure Sensor can be disassembled. The piston assembly and internal bores should be thoroughly cleaned. All seals should be replaced whenever the control is disassembled for maintenance purposes.

A lubricant such as Dow Corning Molykote 33 is recommended for maximum lubrication efficiency. Care should be taken to lubricate the Seals and internal bores lightly.

Once the control is reassembled, function test according to facility test procedures and control circuit application requirements.

REPAIR KIT ITEMS
(SPARE PARTS LIST)

ITEM	PART NAME	PART NUMBER	MATERIAL	QTY. REQ'D
9	O-Ring	AS-010V75	Viton	2
10	O-Ring	AS-008V75	Viton	2
15	Spacer	79705	316SS	1
16	O-Ring	AS-022T(old style)	Teflon	1
16	O-Ring	AS-119T(new style)	Teflon	1
17	O-Ring	AS-008T	Teflon	1
19	O-Ring	AS-012T	Teflon	1
21	O-Ring	AS-006T	Teflon	1

NOTE: Use our Order Number: **HLR 7970T-RK** for a complete Repair Kit whenever it is necessary to replace all of the Pressure Sensor's Seals and items listed above.